

Single Phase Online UPS

Liebert GXT MT+LB
10kVA UPS
User Manual

■ A technical manual
from the experts in
Business-Critical Continuity™



Liebert®

EMERSON™
Network Power



Please comply with all warnings and operating instructions in this manual strictly. Save this manual properly and read carefully the following instructions before installing the unit. Do not operate this unit before reading through all safety information and operating instructions carefully.

Table of Contents

1. SAFETY AND EMC INSTRUCTIONS	3
1-1. TRANSPORTATION AND STORAGE	3
1-2. PREPARATION	3
1-3. INSTALLATION	3
1-4. OPERATION	4
1-5. STANDARDS.....	4
2. INSTALLATION AND OPERATION	5
2-1. UNPACKING AND INSPECTION.....	5
2-2. REAR PANEL VIEW.....	5
2-3. SINGLE UPS INSTALLATION.....	7
2-4. INSTALLATION FOR HOT STANDBY	9
2-5. SOFTWARE INSTALLATION.....	9
3. OPERATIONS.....	10
3-1. BUTTON OPERATION	10
3-2. LED INDICATORS AND LCD PANEL	10
3-3. AUDIBLE ALARM	12
3-4. SINGLE UPS OPERATION.....	12
3-5. ABBREVIATION MEANING IN LCD DISPLAY	16
3-6. LCD DISPLAY	16
3-7. OPERATING MODE/STATUS DESCRIPTION	23
3-8. FAULT CODE	24
3-9. WARNING INDICATOR.....	24
4. TROUBLE SHOOTING	25
5. STORAGE AND MAINTENANCE.....	27
5-1. STORAGE.....	27
5-2. MAINTENANCE	27
6. SPECIFICATIONS	28

1. Safety and EMC instructions

Please read carefully the following user manual and the safety instructions before installing the unit or using the unit!

1-1. Transportation and Storage



Please transport the UPS system only in the original package to protect against shock and impact.



The UPS must be stored in the room where it is ventilated and dry.

1-2. Preparation



Condensation may occur if the UPS system is moved directly from cold to warm environment. The UPS system must be absolutely dry before being installed. Please allow at least two hours for the UPS system to acclimate the environment.



Do not install the UPS system near water or in moist environments.



Do not install the UPS system where it would be exposed to direct sunlight or nearby heater.



Do not block ventilation holes in the UPS housing.

1-3. Installation



Do not connect appliances or devices which would overload the UPS (e.g. big motor-type equipment)) to the UPS output sockets or terminal.



Place cables in such a way that no one can step on or trip over them.



Do not block air vents in the housing of UPS. The UPS must be installed in a location with good ventilation. Ensure enough space on each side for ventilation.



UPS has provided earthed terminal, in the final installed system configuration, equipotential earth bonding to the external UPS battery cabinets.



The UPS can be installed only by qualified maintenance personnel.



An appropriate disconnect device as short-circuit backup protection should be provided in the building wiring installation.



An integral single emergency switching device which prevents further supply to the load by the UPS in any mode of operation should be provided in the building wiring installation.



Connect the earth before connecting to the building wiring terminal.



Installation and Wiring must be performed in accordance with the local electrical laws and regulations.

1-4. Operation



Do not disconnect the earth conductor cable on the UPS or the building wiring terminals in any time since this would cancel the protective earth of the UPS system and of all connected loads.



The UPS system features its own, internal current source (batteries). The UPS output sockets or output terminal blocks may be electrically live even if the UPS system is not connected to the building wiring outlet.



In order to fully disconnect the UPS system, first press the "OFF" button and then disconnect the mains.



Ensure that no liquid or other foreign objects can enter into the UPS system.



The UPS can be operated by any individuals with no previous experience.

1-5. Standards

* Safety	
IEC/EN 62040-1-1	
* EMI	
Conducted Emission.....:IEC/EN 62040-2	Category C3
Radiated Emission.....:IEC/EN 62040-2	Category C3
* EMS	
ESD.....:IEC/EN 61000-4-2	Level 4
RS..... :IEC/EN 61000-4-3	Level 3
EFT..... :IEC/EN 61000-4-4	Level 4
SURGE..... :IEC/EN 61000-4-5	Level 4
CS..... :IEC/EN 61000-4-6	Level 3
Power-frequency Magnetic field..... :IEC/EN 61000-4-8	Level 3
Low Frequency Signals.....:IEC/EN 61000-2-2	
Warning: This is a product for commercial and industrial application in the second environment-installation restrictions or additional measures may be needed to prevent disturbances.	

2. Installation and Operation

There are two different types of online UPS: standard and long-run models. Please refer to the following model table.

Model	Type	Model	Type
10K	Standard Model	10KL	Long Model

2-1. Unpacking and Inspection

Unpack the package and check the package contents. The shipping package contains:

- One UPS
- One user manual
- One monitoring software CD
- One RS-232 cable (option)
- One USB cable
- One battery cable (option)

NOTE: Before installation, please inspect the unit. Be sure that nothing inside the package is damaged during transportation. Do not turn on the unit and notify the carrier and dealer immediately if there is any damage or lacking of some parts. Please keep the original package in a safe place for future use.

2-2. Rear Panel View

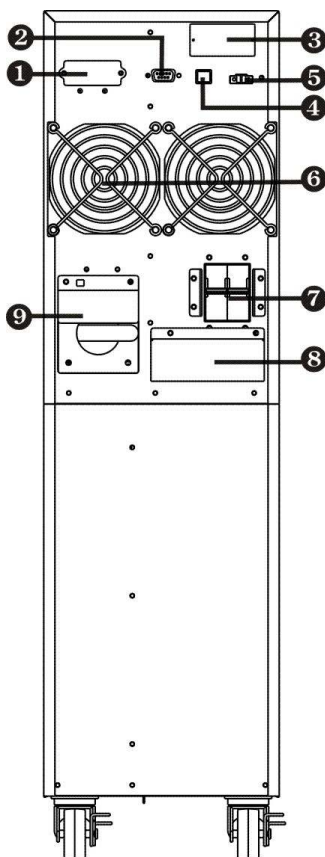

Diagram1: 6K/10K Rear Panel

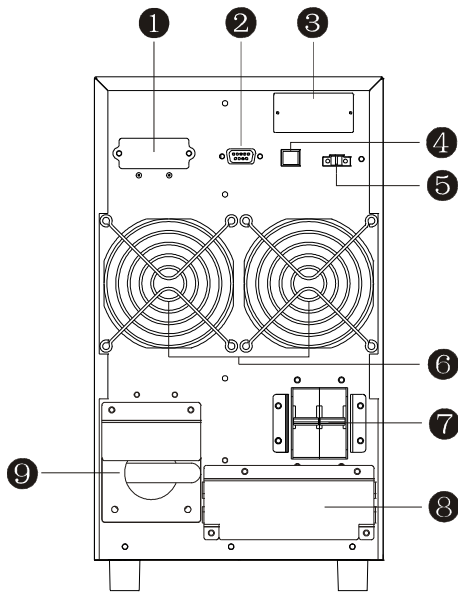

Diagram 2: 6KL/10KL Rear Panel

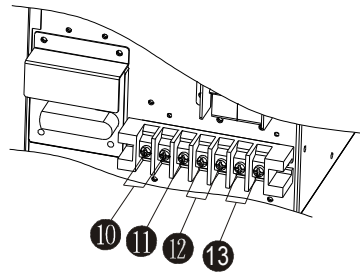

Diagram 3: 6K(L)/10K(L) Input/Output Terminal

1. External battery connector
2. RS-232 communication port
3. Intelligent slot
4. USB communication
5. Emergency power off function connector (EPO connector)
6. Cooling fan
7. Input circuit breaker
8. Input/Output terminal (Refer to Diagram 3 for the details)
9. Maintenance bypass switch
10. Output terminal
11. Grounding terminal
12. Hot standby terminals (BPS/L0)
13. Utility input terminal

2-3. Single UPS Installation

Installation and wiring must be performed in accordance with the local electric laws/regulations and execute the following instructions by professional personnel.

1) Make sure the mains wire and breakers in the building are in compliance with the standard of rated capacity of UPS to avoid the hazards of electric shock or fire.

NOTE: Do not use the wall receptacle as the input power source for the UPS, as its rated current is less than the UPS's maximum input current. Otherwise the receptacle may be burned and destroyed.

- 2) Switch off the mains switch in the building before installation.
- 3) Turn off all the connected devices before connecting to the UPS.
- 4) Prepare wires based on the following table:

Model	Wiring spec (AWG)			
	Input	Output	Battery	Ground
10K	8	8	/	8
10KL	8	8	8	8

NOTE 1: The cable for 6K/6KL should be able to withstand over 50A current. It is recommended to use 10AWG or thicker wire for safety and efficiency.

NOTE 2: The cable for 10K/10KL should be able to withstand over 63A current. It is recommended to use 8AWG or thicker wire for safety and efficiency.

NOTE 3: The selections for color of wires should be followed by the local electrical laws and regulations.

5) Remove the terminal block cover on the rear panel of UPS. Then connect the wires according to the following terminal block diagrams: (Connect the earth wire first when making wire connection. Disconnect the earth wire last when making wire disconnection!)

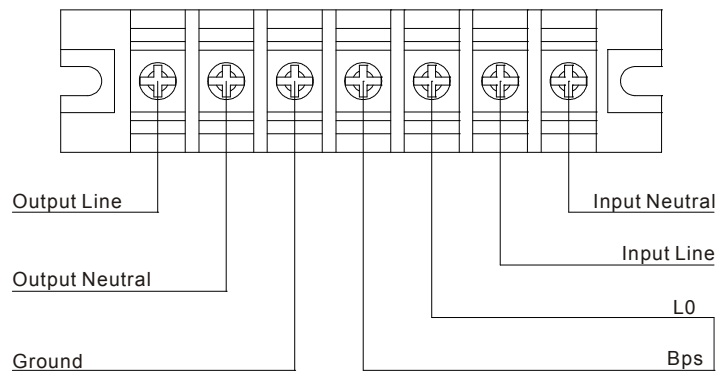

Terminal Block wiring diagram for 6K(L)/10K(L)

NOTE 1: Make sure that the wires are connected tightly with the terminals.

NOTE 2: Please install the output breaker between the output terminal and the load, and the breaker should be qualified with leakage current protective function if necessary.

NOTE 3: For single operation, the terminals of "BPS" and "L0" must be shorted.

6) Put the terminal block cover back to the rear panel of the UPS.



Warning: (Only for standard model)

- Make sure the UPS is not turned on before installation. The UPS should not be turned on during wiring connection.
- Do not try to modify the standard model to the long-run model. Particularly, do not try to connect the standard internal battery to the external battery. The battery type and voltage and numbers may be different. If you connect them together, it maybe causes the hazard of electric shock or fire!



Warning: (Only for long-run model)

- Make sure a DC breaker or other protection device between UPS and external battery pack is installed. If not, please install it carefully. Switch off the battery breaker before installation.



Warning:

- For standard battery pack, there are one DC breaker to disconnect the battery pack and the UPS. But for other external battery pack, make sure a DC breaker or other protection device between UPS and external battery pack is installed. If not, please install it carefully. Switch off the battery breaker before installation.

NOTE: Set the battery pack breaker in "OFF" position and then install the battery pack.

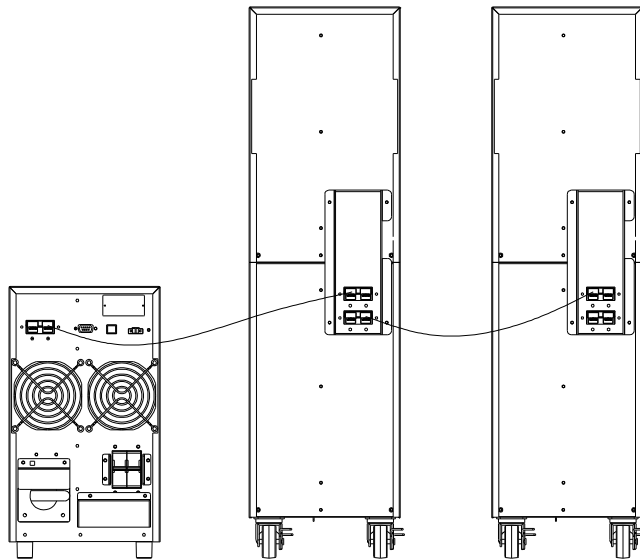

- Pay highly attention to the rated battery voltage marked on the rear panel. If you want to change the numbers of the battery pack, please make sure you modify the setting simultaneously. The connection with wrong battery voltage may cause permanent damage of the UPS. Make sure the voltage of the battery pack is correct.
- Pay highly attention to the polarity marking on external battery terminal block, and make sure the correct battery polarity is connected. Wrong connection may cause permanent damage of the UPS.
- Make sure the protective earth ground wiring is correct. The current spec, color, position, connection and conductance reliability of wire should be checked carefully.
- Make sure the utility input & output wiring is correct. The current spec, color, position, connection and conductance reliability of wire should be checked carefully. Make sure the L/N terminal is correct, not reverse or short-circuited.

2-4. Installation for hot standby

If the hot standby function is not used, you may skip this section.

- 1) Disconnect the jumper wire between the terminals of "BPS" and "L0" on the host UPS.
- 2) Keep the jumper wire between the terminals of "BPS" and "L0" on the standby UPS.
- 3) Connect the "L1" of the standby UPS to the "BPS" of the host UPS.
- 4) Connect the "Output N" of the standby UPS to the "Output N" of the host UPS.

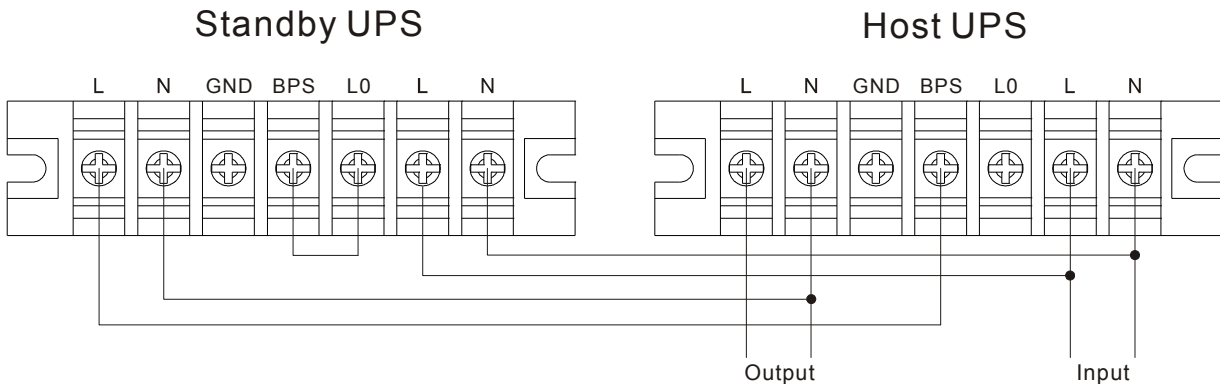

NOTE: Each UPS must be connected to an independent battery pack.

2-5. Software Installation

For optimal computer system protection, install UPS monitoring software to fully configure UPS shutdown.

3. Operations

3-1. Button Operation

Button	Function
ON/Enter Button	<ul style="list-style-type: none"> ➤ Turn on the UPS: Press and hold the button more than 0.5s to turn on the UPS. ➤ Enter Key: Press this button to confirm the selection in setting menu.
OFF/ESC Button	<ul style="list-style-type: none"> ➤ Turn off the UPS: Press and hold the button more than 0.5s to turn off the UPS. ➤ Esc key: Press this button to return to last menu in setting menu.
Test/Up Button	<ul style="list-style-type: none"> ➤ Battery test: Press and hold the button more than 2s to test the battery while in AC mode, or CVCF mode. ➤ UP key: Press this button to display next menu.
Mute/Down Button	<ul style="list-style-type: none"> ➤ Mute the alarm: Press and hold the button more than 2s to mute the buzzer. Please refer to section 3-4-9 for details. ➤ Down key: Press this button to display previous selection.
Test/Up + Mute/Down Button	<ul style="list-style-type: none"> ➤ Press and hold the two buttons simultaneous more than 1s to enter/escape the setting menu.

* CVCF mode means converter mode.

3-2. LED Indicators and LCD Panel

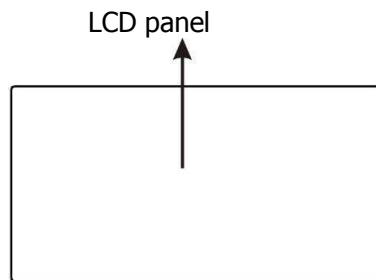

LED Indicators:

There are 4 LEDs on front panel to show the UPS working status:

Mode \ LED	Bypass	Line	Battery	Fault
UPS Startup	●	●	●	●
Bypass mode	●	○	○	○
AC mode	○	●	○	○
Battery mode	○	○	●	○
CVCF mode	○	●	○	○
Battery Test	●	●	●	○
Fault	○	○	○	●



Note: ● means LED is lighting, and ○ means LED is faded.

Note2: If bypass LED flashes in bypass mode, it Indicates that the UPS output is cut off.

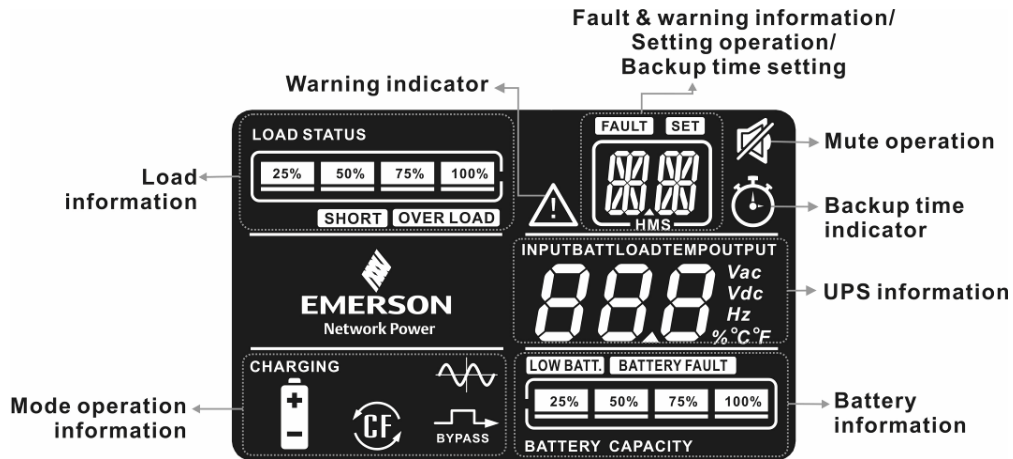
LCD Panel:



Display	Function
Backup time information	
	Indicates the backup time in pie chart.
	Indicates the backup time in numbers. H: hours, M: minute, S: second
Setting operation	
	Indicates the setting operation.
Fault & warning information	
	Indicates that the warning situation occurs.
	Indicates the warning and fault codes, and the codes are listed in details in “Faults Reference Code” and “warning Reference Code” sections.
Mute operation	
	Indicates that the UPS alarm is disabled.
UPS information	
	Indicates the input and output voltage, frequency, battery voltage, load information, and internal temperature. Vac: input/output voltage, Vdc: battery voltage, Hz: frequency, %: load level, °C/°F: temperature,
Load information	
	Indicates the load level by 0-25%, 26-50%, 51-75%, and 76-100%.
	Indicates overload.
	Indicates the load or the UPS output is short circuit.
Mode operation information	
	Indicates the UPS is in online mode.
	Indicates the UPS is in battery mode.
	Indicates the UPS is bypass mode.
	Indicates the UPS is in converter mode.

CHARGING 	Indicates the UPS is charging battery.
Battery information	
 BATTERY CAPACITY	Indicates the Battery capacity by 0-25%, 26-50%, 51-75%, and 76-100%.
BATTERY FAULT	Indicates the battery is fault.
LOW BATT.	Indicates low battery level and low battery voltage.

3-3. Audible Alarm

Description	Buzzer status	Muted
UPS status		
Bypass mode	Beeping once every 2 minutes	Yes
Battery mode	Beeping once every 4 seconds	
Fault mode	Beeping continuously	
Warning		
Overload	Beeping twice every second	No
Low battery	Beeping once every second	
Battery unconnected		
Over charge		
EPO enable		
Fan failure/Over temperature		
Charger failure		
IP fuse broken		
Overload 3 times in 30min		
Cover of maintain switch is open		
Fault		
Bus start failure	Beeping continuously	Yes
Bus over		
Bus under		
Bus unbalance		
Inverter soft start failure		
High Inverter voltage		
Low Inverter voltage		
Inverter output short circuited		
Negative power fault		
Battery SCR short circuited		
Inverter relay short circuited		
Over temperature		
CPU communication failure		
Overload		
Charger short		

3-4. Single UPS Operation

1. Turn on the UPS with utility power supply (in AC mode)

- 1) After power supply is connected correctly, set the breaker of the battery pack at "ON" position (the step only available for long-run model). Then set the input breaker at "ON" position. At this time the fan is

running and the UPS supplies power to the loads via the bypass. The UPS is operating in Bypass mode.

NOTE: When UPS is in Bypass mode, the output voltage will directly power from utility after you switch on the input breaker. In Bypass mode, the load is not protected by UPS. To protect your precious devices, you should turn on the UPS. Refer to next step.

- 2) Press and hold the "ON" button for 0.5s to turn on the UPS and the buzzer will beep once.
- 3) A few seconds later, the UPS will enter to AC mode. If the utility power is abnormal, the UPS will operate in Battery mode without interruption.

NOTE: When the UPS is running out battery, it will shut down automatically at Battery mode. When the utility power is restored, the UPS will auto restart in AC mode.

2. Turn on the UPS without utility power supply (in Battery mode)

- 1) Make sure that the breaker of the battery pack is at "ON" position (only for long-run model).
- 2) Press and hold the "ON" button for 0.5s to turn on the UPS, and the buzzer will beep once.
- 3) A few seconds later, the UPS will be turned on and enter to Battery mode.

3. Connect devices to UPS

After the UPS is turned on, you can connect devices to the UPS.

- 1) Turn on the UPS first and then switch on the devices one by one, the LCD panel will display total load level.
- 2) If it is necessary to connect the inductive loads such as a printer, the in-rush current should be calculated carefully to see if it meets the capacity of the UPS, because the power consumption of this kind of loads is too big.
- 3) If the UPS is overload, the buzzer will beep twice every second.
- 4) When the UPS is overload, please remove some loads immediately. It is recommended to have the total loads connected to the UPS less than 80% of its nominal power capacity to prevent overload for system safety.
- 5) If the overload time is over acceptable time listed in spec at AC mode, the UPS will automatically transfer to Bypass mode. After the overload is removed, it will return to AC mode. If the overload time is over acceptable time listed in spec at Battery mode, the UPS will become fault status. At this time, if bypass is enabled, the UPS will power to the load via bypass. If bypass function is disabled or the input power is not within bypass acceptable range, it will cut off output directly.

4. Charge the batteries

- 1) After the UPS is connected to the utility power, the charger will charge the batteries automatically except in Battery mode or during battery self-test.
- 2) Suggest to charge batteries at least 10 hours before use. Otherwise, the backup time may be shorter than expected time.
- 3) Make sure the battery numbers setting on the control board (Please refer to the section 3-4-12 for detailed setting) is consistent to real connection.
- 4) The charging current can be changed from 0.5A to 6A via LCD or software. Please make sure that the charging current is suitable to battery specification.

5. Battery mode operation

- 1) When the UPS is in Battery mode, the buzzer will beep according to different battery capacity. If the battery capacity is more than 25%, the buzzer will beep once every 4 seconds; If the battery voltage drops to the alarm level, the buzzer will beep quickly (once every sec) to remind users that the battery is at low level and the UPS will shut down automatically soon. Users could switch off some non-critical loads to disable the shutdown alarm and prolong the backup time. If there is no more load to be switched off at that time, you have to shut down all loads as soon as possible to protect the devices or save data. Otherwise, there is a risk of data loss or load failure.
- 2) In Battery mode, if buzzer sound annoys, users can press the Mute button to disable the buzzer.
- 3) The backup time of the long-run model depends on the external battery capacity.
- 4) The backup time may vary from different environment temperature and load type.
- 5) When setting backup time for 16.5 hours (default value from LCD panel), after discharging 16.5 hours, UPS will shut down automatically to protect the battery. This battery discharge protection can be enabled or disabled through LCD panel control. (Refer to 3-7 LCD setting section)

6. Test the batteries

- 1) If you need to check the battery status when the UPS is running in AC mode/CVCF mode, you could press the "Test" button to let the UPS do battery self-test.
- 2) To keep the system reliable, the UPS will perform the battery self-test automatically periodically. The default setting period is once per week.
- 3) Users also can set battery self-test through monitoring software.
- 4) If the UPS is at battery self-test, the LCD display and buzzer indication will be the same as at Battery mode except that the battery LED is flashing.

7. Turn off the UPS with utility power supply in AC mode

- 1) Turn off the inverter of the UPS by pressing "OFF" button for at least 0.5s, and then the buzzer will beep once. The UPS will turn into Bypass mode.

NOTE 1: If the UPS has been set to enable the bypass output, it will bypass voltage from utility power to output sockets and terminal even though you have turned off the UPS (inverter).

NOTE 2: After turning off the UPS, please be aware that the UPS is working at Bypass mode and there is risk of power loss for connected devices.

- 2) In Bypass mode, output voltage of the UPS is still present. In order to cut off the output, switch off the input breaker. A few seconds later, there is no display shown on the display panel and UPS is complete off.

8. Turn off the UPS without utility power supply in Battery mode

- 1) Turn off the UPS by pressing "OFF" button for at least 0.5s, and then the buzzer will beep once.
- 2) Then UPS will cut off power to output and there is no display shown on the display panel.

9. Mute the buzzer

- 1) To mute the buzzer, please press the "Mute" button for at least 0.5s. If you press it again after the buzzer is muted, the buzzer will beep again.
- 2) Some warning alarms can't be muted unless the error is fixed. Please refer to section 3-3 for the details.

10. Operation in warning status

- 1) When Fault LED flashes and the buzzer beeps once every second, it means that there are some problems for UPS operation. Users can get the fault code from LCD panel. Please check the trouble shooting table in chapter 4 for details.
- 2) Some warning alarms can't be muted unless the error is fixed. Please refer to section 3-3 for the details.

11. Operation in Fault mode

- 1) When Fault LED illuminates and the buzzer beeps continuously, it means that there is a fatal error in the UPS. Users can get the fault code from display panel. Please check the trouble shooting table in chapter 4 for details.
- 2) Please check the loads, wiring, ventilation, utility, battery and so on after the fault occurs. Don't try to turn on the UPS again before solving the problems. If the problems can't be fixed, please contact the distributor or service people immediately.
- 3) For emergency case, please cut off the connection from utility, external battery, and output immediately to avoid more risk or danger.

12. Operation of changing battery numbers

- 1) This operation is only available for professional or qualified technicians.
- 2) Turn off the UPS. If the load couldn't be cut off, you should remove the cover of maintenance bypass switch on the rear panel and turn the maintenance switch to "BPS" position first.
- 3) Switch off the input breaker, and switch off the battery breaker (only available for long-run model), or disconnect battery wire for standard model.
- 4) Remove the cabinet cover, and then modify the jumpers (JP1, JS3) on the control board to set the battery numbers as following table:

Battery Number	JP1				JS3
	pin1 & pin2	pin3 & pin4	Pin5 & pin6	pin7 & pin8	
16	X	X	0	0	0
17	X	X	1	1	0
18	X	X	0	0	1
19	X	X	1	0	1
20	X	X	1	1	1

Note : 1 = connect with jumper; 0 = no jumper; x = the pins are for other functions.

- 5) Modify the battery pack for the setting number carefully. After complete it, put the cover back, and switch on the battery breaker for long-run model.
- 6) Switch on the input breaker and the UPS will enter Bypass mode. If the UPS is in maintenance Bypass mode, turn the maintenance switch to "UPS" position and then turn on the UPS.

3-5. Abbreviation Meaning in LCD Display

Abbreviation	Display content	Meaning
ENA	ENR	Enable
DIS	diS	Disable
ATO	AtO	Auto
ON	oN	On
OFF	oFF	Off
FBD	Fbd	Not allowed
OPN	oPN	Allow

3-6. LCD Display

3-6-1. LCD Main Interface

A. Single model: Press up and down key to select the displayed information.

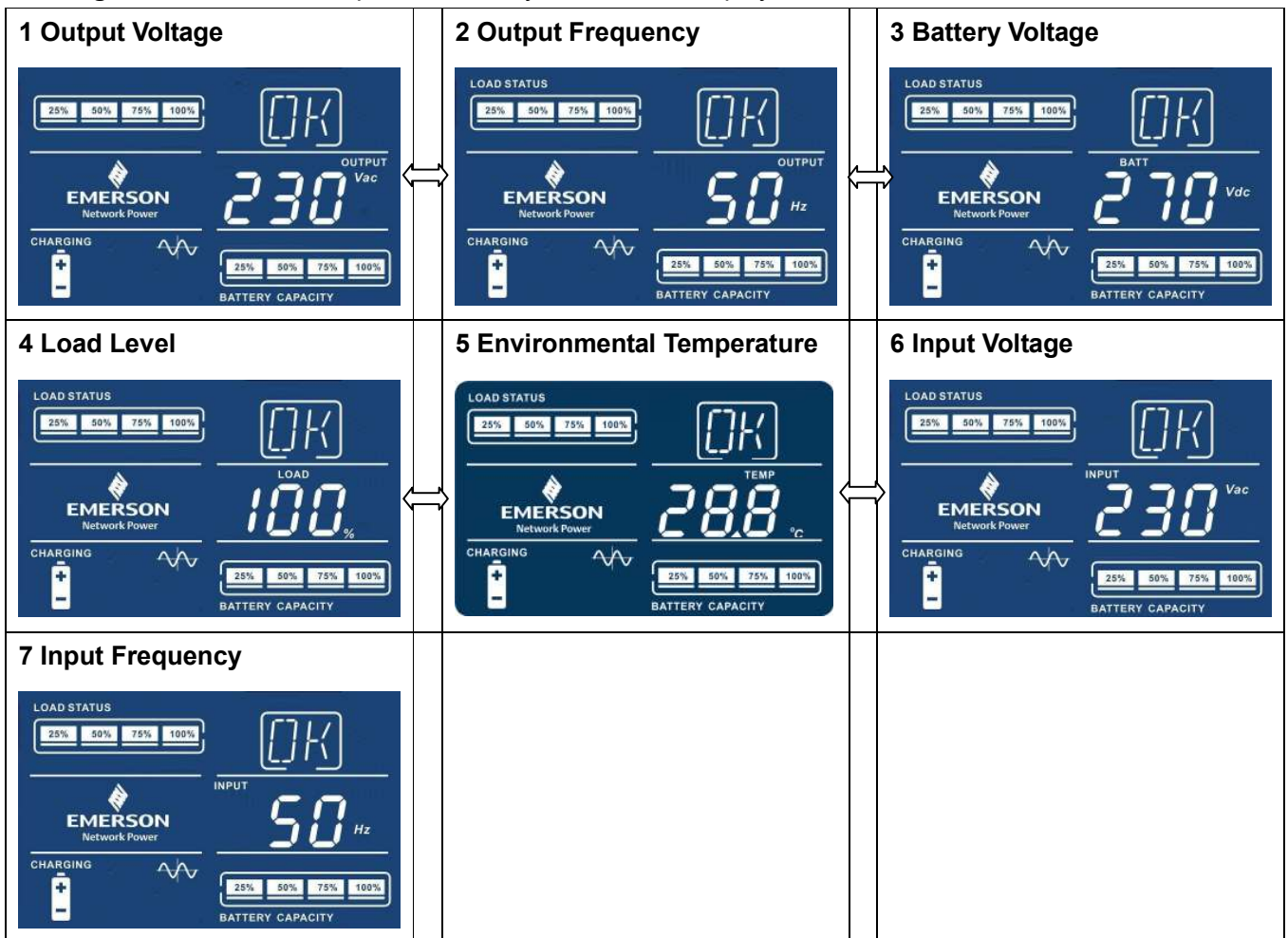

3-6-2. LCD Setting

At the main interface; press and hold the “up” and “down” buttons simultaneous for more than 1 second to enter or escape from setting menu.

There are two parameters to set up the UPS. Refer to following diagram.

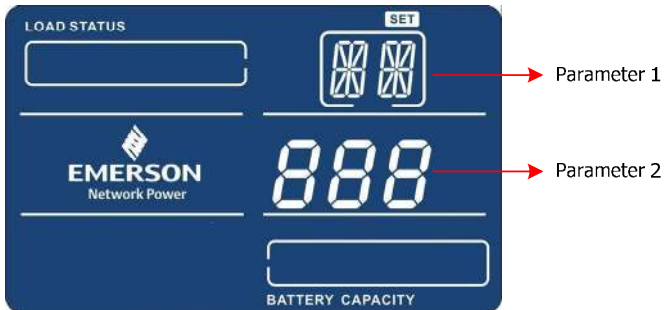

Parameter 1: It's for program alternatives. Refer to below table for the details.

Parameter 2: Setting options or values for each program.

11 programs available list for parameter 1:

Code	Description	Bypass	AC	CVCF	Battery	Battery Test
01	Output voltage	Y				
02	CVCF mode enable/disable	Y				
03	Output frequency	Y				
04	Bypass mode open/forbidden	Y	Y			
05	Bypass mode enable/disable	Y	Y			
06	Battery backup time setting	Y	Y	Y	Y	Y
07	Hot standby function enable/disable	Y	Y	Y	Y	Y
08	Voltage range for bypass –low loss	Y				
09	Voltage range for bypass –high loss	Y				
10	Frequency range for bypass –low loss	Y				
11	Frequency range for bypass –high loss	Y				
12	Battery voltage Calibration	Y	Y	Y	Y	Y
13	Charger voltage adjustment	Y	Y	Y	Y	Y
14	Inverter voltage Calibration		Y	Y	Y	
15	Charger maximum current setting	Y	Y	Y	Y	Y
16	Battery capacity setting	Y	Y	Y	Y	Y
17	Battery groups setting	Y	Y	Y	Y	Y
18	Backup time calibration	Y	Y	Y	Y	Y

*Y means that this program can be set in this mode.

● 01: Output voltage

Interface	Setting
	<p>Parameter 2: Output voltage You may choose the following output voltage in parameter 3: 208: Presents output voltage is 208Vac 220: Presents output voltage is 220Vac 230: Presents output voltage is 230Vac 240: Presents output voltage is 240Vac</p>

● 02: Frequency Converter enable/disable

Interface	Setting
	<p>Parameter 2: Frequency mode Setting output frequency at CVCF mode or not CVCF mode. You may choose following two options in parameter 3: ENA: Setting UPS to CVCF mode. If selected, the output frequency will be fixed at 50Hz or 60Hz according to “Output frequency setting”. The input frequency could be from 46Hz to 64Hz. DIS: Setting UPS to normal mode (not CVCF mode). If selected, the output frequency will synchronize with the input frequency within 46~54 Hz at 50Hz or within 56~64 Hz at 60Hz according to setting in “Output frequency setting”. If 50 Hz is selected in “Output frequency setting”, UPS will transfer to battery mode when input frequency is not within 46~54 Hz. If 60 Hz is selected in “Output frequency setting”, UPS will transfer to battery mode when input frequency is not within 56~64 Hz.</p>

● 03: Output frequency setting

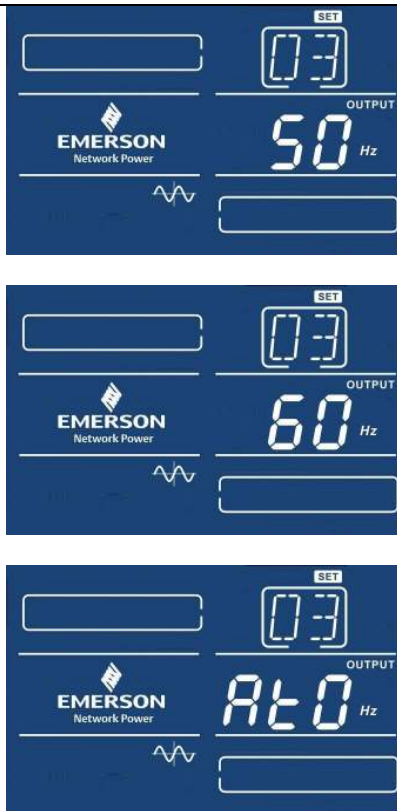
Interface	Setting
	<p>Parameter 2: Output Frequency 50.0Hz: The output frequency is setting for 50.0Hz. 60.0Hz: The output frequency is setting for 60.0Hz. ATO: If selected, output frequency will be changed based on the latest input utility frequency. If it is within 46Hz and 54Hz, the output frequency will be 50.0Hz. If it is within 56Hz and 64Hz, the output frequency will be 60.0Hz. ATO is default setting.</p> <p>If converter mode is enabled and output frequency is set to ATO mode, it will display “A50” when UPS is working on 50Hz mode or “A60” when UPS is working on 60Hz mode in LCD.</p>

● 04: Bypass mode forbidden/allowed

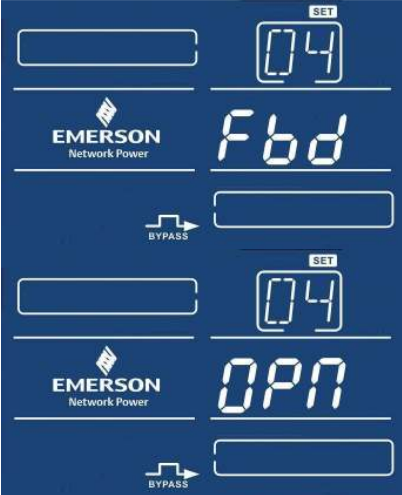
Interface	Setting
 <p>The screenshot shows two screens of the Emerson Network Power interface. The top screen displays '04' in the top right corner, with 'Fbd' in the center and an empty input field below. The bottom screen displays '04' in the top right corner, with 'OPN' in the center and an empty input field below. Both screens feature the Emerson Network Power logo and a 'BYPASS' button icon at the bottom.</p>	<p>Parameter 2: Allow or forbidden bypass mode FBD: Bypass not allowed. When selected, it's not allowed for running in Bypass mode under any situations. OPN: Bypass allowed. When selected, UPS will run at Bypass mode depending on the setting of “Switch off Bypass mode enable/disable”.</p>

● **05: Manual bypass enable/disable**

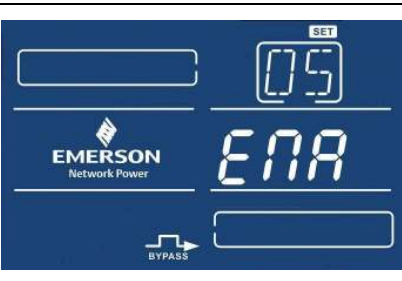
Interface	Setting
 <p>The screenshot shows the Emerson Network Power interface with '05' in the top right corner, 'ENA' in the center, and an empty input field below. The Emerson Network Power logo and 'BYPASS' button icon are also visible.</p>	<p>Parameter 2: ENA: Bypass enabled. When selected, bypass mode is activated. DIS: Manual bypass disabled. When selected, automatic bypass is acceptable, but manual bypass* is not allowed. *Manual bypass means users manually operate UPS in Bypass mode. For example, pressing OFF button in AC mode to turn into Bypass mode.</p>

● **06: Battery backup time setting**

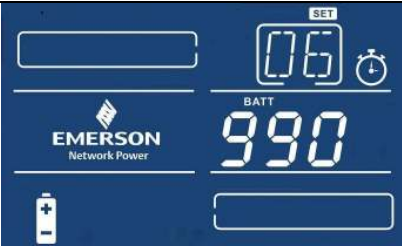
Interface	Setting
 <p>The screenshot shows the Emerson Network Power interface with '06' in the top right corner, '990' in the center, and a battery icon below. The Emerson Network Power logo and 'BYPASS' button icon are also visible.</p>	<p>Parameter 2: 000~999: Set the maximum backup time from 0 min to 999 min. UPS will shut down to protect battery after backup time arrives. The default value is 990. DIS: Disable battery discharge protection and backup time will depend on battery capacity.</p>

● **07: Hot standby function enable/disable**

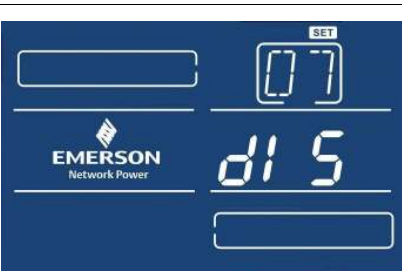
Interface	Setting
 <p>The screenshot shows the Emerson Network Power interface with '07' in the top right corner, 'DIS' in the center, and an empty input field below. The Emerson Network Power logo and 'BYPASS' button icon are also visible.</p>	<p>Parameter 2: Enable or disable hot standby function. ENA: Hot standby function is enabled. It means that the current UPS is set to host of the hot standby function, and it will restart after AC recovery even without battery connected. DIS: Hot standby function is disabled. The UPS is running at normal mode and can't restart without battery.</p>

● **08: Voltage range for bypass**

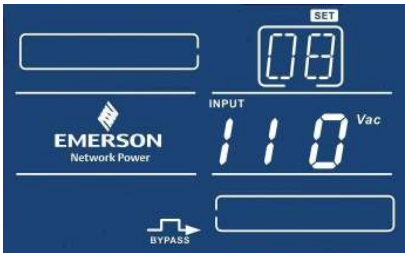
Interface	Setting
	<p>Parameter 2: Set the acceptable low voltage for bypass. Setting range is from 110V to 209V and the default value is 176V</p>

● **09: Voltage range for bypass**

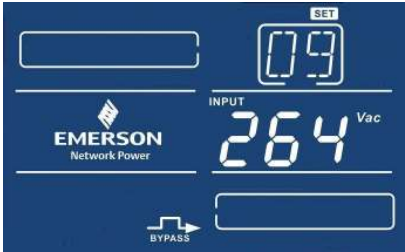
Interface	Setting
	<p>Parameter 2: Set the acceptable low voltage for bypass. Setting range is from 231V to 276V and the default value is 264V</p>

● **10: Frequency range for bypass**

Interface	Setting
	<p>Parameter 2: Set the acceptable low frequency for bypass. 50 Hz system: Setting range is from 46.0Hz to 49.0Hz. 60 Hz system: Setting range is from 56.0Hz to 59.0Hz. The default value is 46.0Hz/56.0Hz.</p>

● **11: Frequency range for bypass**

Interface	Setting
	<p>Parameter 2: Set the acceptable high frequency for bypass. 50 Hz: Setting range is from 51.0Hz to 54.0 Hz. 60 Hz: Setting range is from 61.0Hz to 64.0Hz. The default value is 54.0Hz/64.0Hz.</p>

● **12: Battery voltage calibration**

Interface	Setting

	<p>Parameter 2: Set Battery voltage calibration. the voltage range is from -5.7V to 5.7V.the default value is 0V.</p>
--	--

● **13: charger voltage calibration**

Interface	Setting
	<p>Parameter 2: Set charger voltage calibration. the voltage range is from -6.4V to 6.4V, the default value is 0V.</p>

● **14: Inverter voltage calibration**

Interface	Setting
	<p>Parameter 2: Set Inverter voltage calibration. the voltage range is from -6.4V to 6.4V, the default value is 0V.</p>

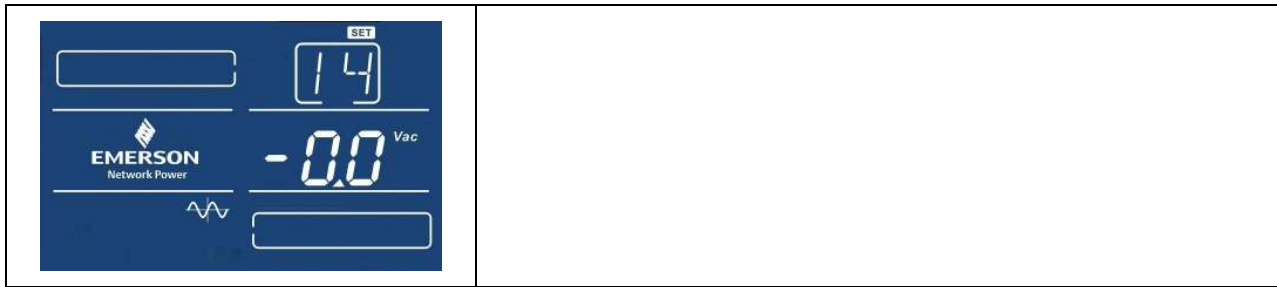

● **15: Charger maximum current setting**

Interface	Setting
	<p>Parameter 2: The maximum charging current could be adjusted. Default value is 4A for long run model and 1A for standard model. The setting range is 0.5A~6A for long run model, and 0.5A~2A for standard model</p> <p>Note: Any modification should be suitable to battery specifications. If input voltage is below 200VAC, the UPS will reduce charging current to 4A automatically even though the setting is 6A.</p>

● **16: Battery capacity setting**

Interface	Setting
	<p>Parameter 2: Set the battery capacity such as 7AH, 9AH, 10AH, 12AH, 17AH, 26AH, 40AH, 65AH, 100AH and so on. The default value is 9AH.</p>



● **17: Battery groups setting**

Interface	Setting
	<p>Parameter 2: Set battery group range from 1 to 6. The default value is 1 group. These parameters are for the battery backup time calculation</p>

● **18: Backup time calibration**

Interface	Setting
	<p>Parameter 2: Calibrate the displayed backup time by adjusting this multiplier factor. The displayed backup time will be equal with the original calculated backup time multiply this value. The default value is 1.0, and the range is from 0.5 to 2</p>

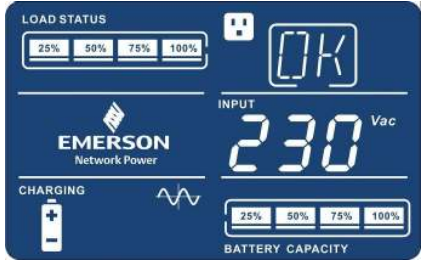
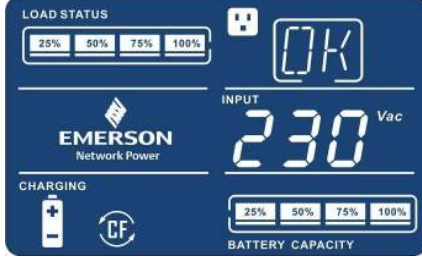
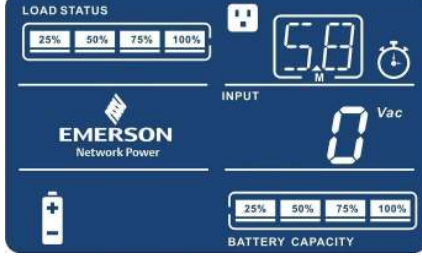
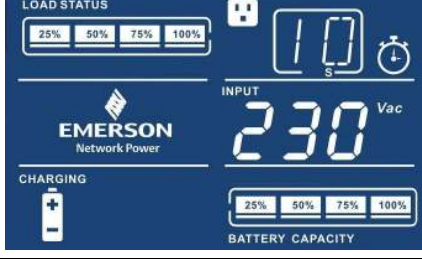











3-7. Operating Mode/Status Description

Operating mode/status	Description	LCD display
AC mode	When the input voltage is within acceptable range, UPS will provide pure and stable AC power to output. The UPS will also charge the battery at AC mode.	
CVCF mode	When input frequency is between 46Hz and 64Hz, the UPS can be set at a constant output frequency, 50 Hz or 60 Hz. The UPS will still charge battery under this mode.	
Battery mode	When the input voltage is beyond the acceptable range or power failure, UPS will backup power from battery and alarm will beep every 4 seconds.	
Battery Test	When UPS is in AC mode or CVCF mode, press "Test" key for more than 2 seconds. Then, UPS will beep once and start "Battery Test". This operation is used to check the battery status.	
Bypass mode	When input voltage is within acceptable range and bypass is enabled, turn off the UPS and it will enter Bypass mode. Alarm beeps every two minutes.	
Fault status	When fault occurs in UPS, it will display fault icon and fault code in LCD panel.	

3-8. Fault Code











Fault event	Fault code	Icon	Fault event	Fault code	Icon
Bus start failure	01	None	Battery SCR short circuited	21	None
Bus over	02	None	Inverter relay short circuited	24	None
Bus under	03	None	Charger output short	2A	None
Bus unbalance	04	None	Parallel communication failure	35	None
Inverter soft start failure	11	None	Parallel output current unbalance	36	None
High Inverter voltage	12	None	Over temperature	41	None
Low Inverter voltage	13	None	CPU communication failure	42	None
Inverter output short circuited	14	SHORT	Overload	43	OVER LOAD
Negative power fault	1A	None			

3-9. Warning Indicator

Warning Description	code	Icon (flashing)	Alarm
Battery is not connected	01	 BATTERY FAULT	Beeping every second
Over charge	07	 	Beeping every second
Low battery	08	 LOW BATT.	Beeping every second
Overload	09	 OVER LOAD	Beeping twice every second
Fan failure	0A		Beeping every second
EPO enabled	0B		Beeping every second
Over temperature	0D		Beeping every second
Charger failure	0E	 	Beeping every second
I/P fuse broken	10		Beeping every second
Overload 3 times in 30 minutes	33	 OVER LOAD	Beeping every second
Cover of maintain switch is open	3A		Beeping every second

4. Trouble Shooting

If the UPS system does not operate correctly, please solve the problem by referring to the table below:

Alarm type	Code	Icon	Possible cause	Remedy
Warning	01		<ol style="list-style-type: none"> 1) The battery is not connected well; 2) The battery protection device is open. 	<ol style="list-style-type: none"> 1) Connect the battery well; 2) Replace or restore the protection device.
Warning	07		<ol style="list-style-type: none"> 1) Battery numbers and its setting is not matching; 2) Charger voltage is too high. It will cause charger failure. 	<ol style="list-style-type: none"> 1) Correct the battery number or its setting; 2) Disconnect the battery and check the charger output voltage. Then, contact the dealer for repair.
Warning	08		<ol style="list-style-type: none"> 1) Battery is discharged deeply to low voltage. 2) Battery number is not correct. 3) Battery is in the end of life. 	<ol style="list-style-type: none"> 1) Recharge the battery. 2) Correct the battery number. 3) Replace the battery.
Warning	09		Overload.	Remove excess loads from UPS output.
Warning	0A		<ol style="list-style-type: none"> 1) Fan is blocked. 2) Fan is in the end of life. 3) Fan circuit failed. 	<ol style="list-style-type: none"> 1) Clean fan to make sure it is not blocked. 2) Contact the dealer to replace the fan. 3) Contact the dealer for repair.
Warning	0B		EPO plug (jumper) is removed or the external EPO switch is off.	Connect the EPO plug (jumper) well or switch on the external EPO switch.
Warning	0D		<p>The internal temperature is too high and reaches warning level:</p> <ol style="list-style-type: none"> 1) Maybe the environment is hot. 2) Maybe the fan is blocked or failed. 3) Maybe the ventilation is blocked by the wall or other goods. 4) Overload 	<ol style="list-style-type: none"> 1) Make sure the ambient temperature is not over 40°C. 2) Make sure the fan is OK. 3) Make sure ventilation is well. 4) Remove some loads if possible.
Warning	0E		Charger failure.	Contact the dealer for repair.
Warning	10		Input fuse on the power stage board is blown.	Check and replace the input fuse.
Warning	33		Locked in bypass after overload 3 times in 30 minutes.	Remove excess loads from UPS output first, then shut down the UPS and restart it.
Warning	3A		Cover of maintain switch is open.	Please put the cover back.

Alarm type	Code	Icon	Possible cause	Remedy
Fault	01	FAULT	The internal converter failed, so the DC bus voltage could not be boosted correctly.	Contact the dealer for repair
Fault	02	FAULT	1) The mains input or load transient current cause the DC bus voltage too high. 2) The internal converter failed.	1) Shut down and restart the UPS to see if it happens again. If the problem still persists, please contact the dealer for repair. 2) Contact the dealer for repair.
Fault	03	FAULT	The internal converter fails, so the DC bus voltage is too low.	Contact the dealer for repair.
Fault	04	FAULT	1) The load is special or abnormal, so the internal positive and negative DC bus voltages are unbalanced; 2) The internal converter failed.	Contact the dealer.
Fault	11	FAULT	The internal inverter fails, so the inverter voltage could not start up correctly.	Contact the dealer for repair.
Fault	12	FAULT	The internal inverter fails, so the inverter voltage is too high.	Contact the dealer for repair.
Fault	13	FAULT	The internal inverter fails, so the inverter voltage is too low.	Contact the dealer for repair.
Fault	14	FAULT	Short circuit occurs on the UPS output.	Remove short circuited output/situation. If the problem still persists, please contact the dealer for repair.
Fault	1A	FAULT	UPS output power is negative. It means there is energy feedback into the internal of UPS from output. It may be caused by regenerative load or the current control failure in the parallel system.	Contact the dealer.
Fault	21	FAULT	The internal battery SCR failed and short circuited.	Contact the dealer for repair.
Fault	2A	FAULT	Short circuit occurs on the charger output.	Remove short circuited output/situation. If the problem still persists, please contact the dealer for repair.
Fault	24	FAULT	The internal inverter relay is stick to short circuited or the SCR of STS (Static Transfer Switch) is short-circuited.	Contact the dealer for repair.
Fault	41	FAULT	The internal temperature is too high and reaches the fault level (shutdown point): 1) Maybe the environment is hot. 2) Maybe the fan is blocked or failed. 3) Maybe the ventilation is blocked by the wall or other goods. 4) Overload	1) Make sure the ambient temperature not over 40°C; 2) Make sure the fan is OK; 3) Make sure the ventilation is well; 4) Remove some loads if possible.
Fault	42	FAULT	Internal communication between the CPUs failed	Contact the dealer for repair.
Fault	43	FAULT	Overload times are out of the specification and the UPS shuts down automatically.	Remove excess loads from UPS output and restart it.

5. Storage and Maintenance

5-1. Storage

Before storing, charge the UPS at least 7 hours. Store the UPS covered and upright in a cool, dry location.

During storage, recharge the battery in accordance with the following table:

Storage Temperature	Recharge Frequency	Charging Duration
-25°C - 40°C	Every 3 months	1-2 hours
40°C - 45°C	Every 2 months	1-2 hours

5-2. Maintenance



The UPS system operates with hazardous voltages. Repairs may be carried out only by qualified maintenance personnel.



Even after the unit is disconnected from the mains, components inside the UPS system are still connected to the battery packs which are potentially dangerous.



Before carrying out any kind of service and/or maintenance, disconnect the batteries and verify that no current is present and no hazardous voltage exists in the terminals of high capability capacitor such as BUS-capacitors.



Only persons are adequately familiar with batteries and with the required precautionary measures may replace batteries and supervise operations. Unauthorized persons must be kept well away from the batteries.



Verify that no voltage between the battery terminals and the ground is present before maintenance or repair. In this product, the battery circuit is not isolated from the input voltage. Hazardous voltages may occur between the battery terminals and the ground.



Batteries may cause electric shock and have a high short-circuit current. Please remove all wristwatches, rings and other metal personal objects before maintenance or repair, and only use tools with insulated grips and handles for maintaining or repairing.



When replace the batteries, install the same number and same type of batteries.



Do not attempt to dispose of batteries by burning them. This could cause battery explosion. The batteries must be rightly deposited according to local regulation.



Do not open or destroy batteries. Escaping electrolyte can cause injury to the skin and eyes. It may be toxic.



Please replace the fuse only with the same type and amperage in order to avoid fire hazards.



Do not disassemble the UPS system.

6. Specifications

MODEL		GXT MT+ LB, 10kVA
CAPACITY*		10000 VA / 8000 W
INPUT		
Voltage Range	Low Line Loss	110 VAC \pm 3 % at 50% Load; 176 VAC \pm 3 % at 100% Load
	Low Line Comeback	Low Line Loss Voltage + 10V
	High Line Loss	300 VAC \pm 3 %
	High Line Comeback	High Line Loss Voltage - 10V
Frequency Range		46Hz ~ 54 Hz @ 50Hz system 56Hz ~ 64 Hz @ 60Hz system
Phase		Single phase with ground
Power Factor		> 0.99 at 100% Load
OUTPUT		
Output voltage		208/220/230/240VAC
AC Voltage Regulation		\pm 1%
Frequency Range (Synchronized Range)		46Hz ~ 54 Hz @ 50Hz system 56Hz ~ 64 Hz @ 60Hz system
Frequency Range (Batt. Mode)		50 Hz \pm 0.1 Hz or 60Hz \pm 0.1 Hz
Overload	AC mode	100%~110%: 10min、110%~130%: 1min、>130% : 1sec
	Battery mode	100%~110%: 30sec、110%~130%: 10sec、>130% : 1sec
Current Crest Ratio		3:1 max
Harmonic Distortion		\leq 3 % @ 100% Linear Load; \leq 6 % @ 100% Non-linear Load
Transfer Time	Line \longleftrightarrow Battery	0 ms
	Inverter \longleftrightarrow Bypass	0 ms
EFFICIENCY		
AC mode		> 90%
Battery Mode		> 89%
BATTERY		
Standard Model	Type & Numbers	12 V / 9 Ah x 20
	Recharge Time	9 hours recover to 90% capacity
	Charging Current	Default : 1 A \pm 10% Max.: 2A \pm 10%
	Charging Voltage	14.4 V \pm 1%
Long-run Model	Type	Depending on applications
	Numbers	16 – 20 Derating capacity = original real power capacity x N/20
	Charging Current	Default: 4 A \pm 10% Max.: 6A \pm 10%
	Charging Voltage	14.4 V \pm 1%
PHYSICAL		
Standard Model	Dimension, DXWXH(mm)	442x 190 x 688
	Net Weight (kgs)	82
Long-run Model	Dimension, DXWXH(mm)	442x 190 x 318
	Net Weight (kgs)	23
ENVIRONMENT		
Operation Temperature		0 ~ 40°C (battery life cycle will be shorten when temperature is above 25°C)
Operation Humidity		<95 % and non-condensing
Operation Altitude**		<1000m
Acoustic Noise Level		Less than 58dB @ 1 Meter
MANAGEMENT		
Smart RS-232 or USB		Supports Windows® 2000/2003/XP/Vista/2008, Windows® 7, Linux, Unix, and MAC
Optional SNMP		Power management from SNMP manager and web browser

* Derate capacity to 60% of capacity in CVCF mode and to 90% when the output voltage is adjusted to 208VAC.

**If the UPS is installed or used in a place where the altitude is above than 1000m, the output power must be derated one percent per 100m.

***Product specifications are subject to change without further notice.

Emerson Network Power.

The global leader in enabling *Business-Critical Continuity™*.

- AC Power
- Embedded Computing
- Connectivity
- Embedded Power
- DC Power
- Infrastructure Management & Monitoring

- Outside Plant
- Power Switching & Controls
- Precision Cooling

EmersonNetworkPower.com

- Racks & Integrated Cabinets
- Services
- Surge Protection